

40RTS JLG, SCISSOR LIFT Specifications

40RTS JLG

STANDARD FEATURES	
• Movable, removable platform control box	• Descent alarm
• Heavy gauge steel chassis compartment hoods	• 4ft (1.22m) manual deck extension
• 3 degree slope alarm and light	• 110V-AC receptacle in platform
• Horn	• Scissor maintenance prop
• Lubrication free scissor arm brushing	• Manual descent pull cable
• Fold-down handrails on extension deck and removable main handrails	• Proportional hydrostatic drive control w/thumb steer
• Ground control console with hourmeter, water temperature gauge, oil pressure gauge, and voltmeter	

DIMENSIONAL DATA	
A Platform Height Elevated	39ft 6 in (121m)
B Platform Height Lowered	5 ft 8 in (1.73 m)
C Railing Height	435in (110m)
D Overall Height (rails lowered)*	8 ft. 2 in. (2.49 m)
E Platform Dimensions	71 in x 126 in (1.80 x 3.20 m)
F Deck Extension	4ft (1 23 m)
G Overall Width	7 ft 6 in (2.29 m)
H Overall Length	12ft 8in (3.86 m)
I Wheelbase	98 in (2.50 m)
J Ground Clearance	12 in (0.30 m)
Capacity	1,000 lbs (454 kg)
Capacity with Optional Deck Extension	750 lbs (340 kg)
Capacity on Optional Deck Extension	500 lbs (227 kg)
Lift/Lower Speed	65/35 sec
Maximum Drive Height	full height
4 ft Front Deck Extension	optional manual
Platform Material	steel tread plate

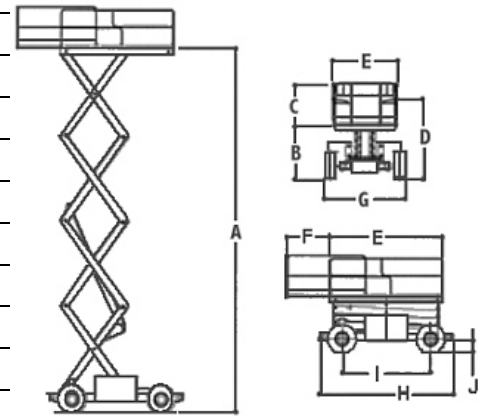

CHASSIS	
Drive Speed – 2 Wheel Drive	3.5 mph (5 6 kph)
Gradeability – 2 Wheel Drive	35%
Turning Radius (inside) – 2 Wheel Steer	12 ft 6 in (3.81m)
Turning Radius (outside) – 2 Wheel Steer	18 ft 1 in (5 51 m)
Tire Size	12x165
Tire Type	air
Brakes	spring applied multi disc

POWER SYSTEM	
Dual Fuel	
Gross Vehicle Weight	9,200 lbs. (4,175 kg)