

# HD 14 VV / VT



## Articulated tandem roller

- ▶ Optimal view due to concave front end
- ▶ Excellent view to the drum edges
- ▶ Ergonomic driver's platform, low working platform
- ▶ Modern instrument panel
- ▶ Low machine height
- ▶ 3-point swivel joint for outstanding driving comfort
- ▶ Crab steering
- ▶ Central suspension point
- ▶ Very easy maintenance, long service intervals



# HD 14 VV / HD 14 VT



TECHNICAL DATA	HD 14 VV	HD 14 VT
----------------	----------	----------

Weights			
Operating weight	kg	4195	3775
Maximum weight	kg	4700	4300
Axle load, front/rear	kg	2065/2130	2065/1710
Load per tire, rear	kg		427,5
Static linear load, front/rear	kg/cm	15,0/15,4	
Static linear load, front	kg/cm		15,0
Machine dimensions			
Max. working width	mm	1430	1380
Turning radius, inside	mm	2602	2602
Size of tires, rear			10,5/80-16
Diesel engine			
Manufacturer		HATZ	HATZ
Type		4W35T	4W35T
Number of cylinders		4	4
Power rat. DIN/ISO3046IFN kW/PS/rpm		29,4/40,0/2800	29,4/40,0/2800
Power rating SAE J1349, kW/HP/rpm		29,4/39,4/2800	29,4/39,4/2800
Drive			
Hydrostatic drive, front/rear		Hydr. motor/hydr. motor	Hydr. motor/hydr. motor
Speed, infinitely variable	km/h	0 - 10,0	0 - 10,0
Climbing ability, vibration on/off	%	30/40	30/40
Vibration system			
Hydrostatic drive. Front and rear vibration one and double switch (VV), automatic vibration switch-off at overspeed. Manual or automatic vibration control.			
Vibration			
Vibration frequency, front, I/II	Hz	61/61	61/61
Vibration frequency, rear, I/II	Hz	61/61	
Amplitude, front, I/II	mm	0,52/0,32	
Amplitude, rear, I/II	mm	0,52/0,32	
Amplitude, front, I/II	mm		0,52/0,32
Centrifugal force, front, I/II	kN	65/40	
Centrifugal force, rear, I/II	kN	65/40	
Centrifugal force, front, I/II	kN		65/40
Steering			
Steering, type		Pivoted steering	Pivoted steering
Steering, actuation		hydrostatic, steer. wheel	hydrostatic, steer. wheel
Steering lock +/-	Grad	33	33
Oscillation angle +/-	Grad	8	8
Brake system			
Service brake, mode of action		hydrostatic	hydrostatic
Service brake, actuation		Drive lever	Drive lever
Parking brake, mode of action		Spring-loaded/mechanical	Spring-loaded/mechanical
Parking brake, actuation		electr. a. autom.	electr. a. autom.
Emergency brake, mode of action		hydr./mech.	hydr./mech.
Emergency brake, actuation		Emergency stop	Emergency stop
Sprinkler system			
Water sprinkler, type		Pressure	Pressure
Actuation, sprinkling		interval/manual	interval/manual
Water tank, capacity	Ltr.	290	290
Additive tank, capacity	Ltr.		20

**Equipment**  
50 mm crab steering, suspended driver seat, comfort seat with safety belt, 2 multifunctional control levers, hour meter, pilot lamps and emergency stop device, CE-conformity.

**Optional**  
Lighting according to German Road Regulation, 2 working lamps on ROPS, backup alarm, rotating beacon, special paint, sun top, ROPS, edge pressing and cutting equipment, super noise insulation.

Further data on request / subject to change

HD 14 VV - Articulated tandem roller  
HD 14 VT - Articulated combination tandem roller

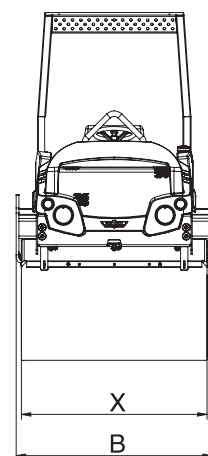
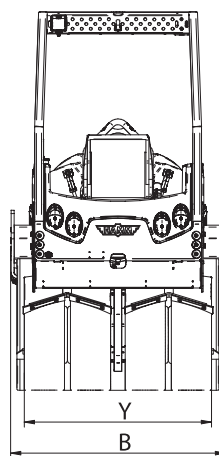
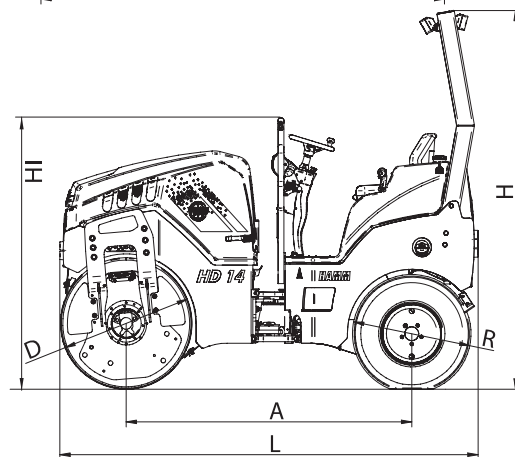
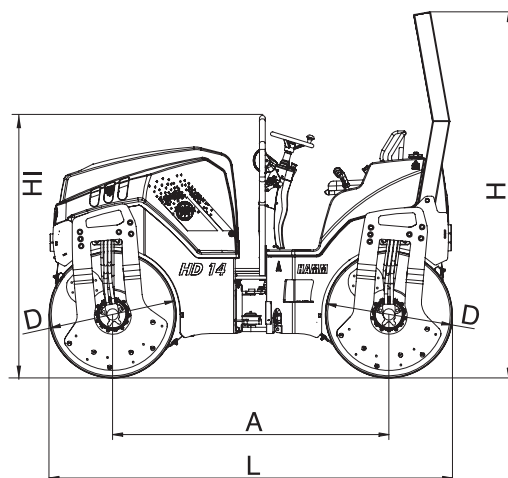

		HD 14 VV	HD 14 VT
Total length	L	2856	2856
Width	B	1506	1506
Total height	H	2585	2585
Wheel base	A	1950	1950
Roller drum width	X	1380	1380
Drum diameter	D	898	898
Width over tires	Y		1280
Diameter of tires	R		810
Height loading, min.	HI	1853	1853