

DRIVE THE CHANGE



LITHIUM



BR.2018.02.0085.02.03

CORMIDI

C85

MINI TRACK DUMPER



DRIVE THE CHANGE

MAXIMUM EFFICIENCY



Endless hours of testing and fine tuning made the C85 the best in its class for performance and reliability. We created a durable machine with maintenance cost close to none.

UNDERCARRIAGE



Our undercarriage is like no one. Our Cormidi R&D department put all its experience towards creating the best undercarriage available on the market

SIMPLY INCREDIBLE



The Cormidi design lab created a machine that mixes industrial design with strength, power and easy to use

CORMIDI

C85
MINI TRACK DUMPER



DRIVE THE CHANGE

STRENGTHS



The C85 puts incredible power in a compact and sturdy machine



The operators has a perfect access to all the controls and can keep all the parameters under control



The swinging bucket not only load the dumper but can unload it frontally



The air cooling system allows the machine to operate in extreme conditions



High performance battery pack Life P04, Bms System



Greasing the undercarriage is easy and fast: nothing has to be taken apart.



Electronic control unit battery management software devel. by Cormidi allows for high perfor. and unparalleled battery life. Cormidi also patented an algorithm that allows for both speed and a boost like a hyd. machine as well as softness and precision of movements unique of its kind.



Galvanized sheet, protects the moving parts from materials that could damage them



When the situation needs a shorter unit, the stand can be closed, otherwise it opens to let the operator in.

STRENGTHS



REMOTE CONTROL

The machine can be radio controlled for dangerous jobs.



HOOKS

Large and sturdy hooks to move the machine in total safety.



ROCKING ROLLS

The machine's undercarriage oscillated to follow the terrain profile for increased stability and comfort.



CORMIDI COCKPIT

Display 3.5 "touch screen

Display 3.5 "touch screen allows you to view all the settings of the machine as well as choosing the level of power and speed of the machine.

From the display you can select 3 power and speed modes:

- **Std normal speed** long battery life.
- **PF (Performance mode)** Medium high speed and power increase
- **HP (Hyper Performance)** High speed and high traction power.



BATTERY QUICK SHIFT SYSTEM

1

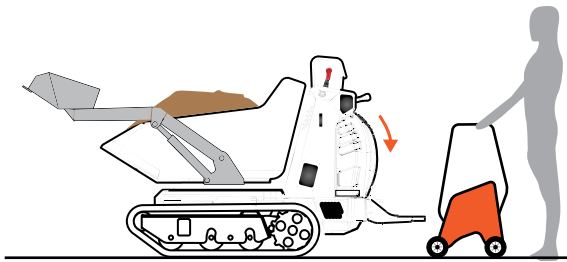

OPEN THE BONNET

2

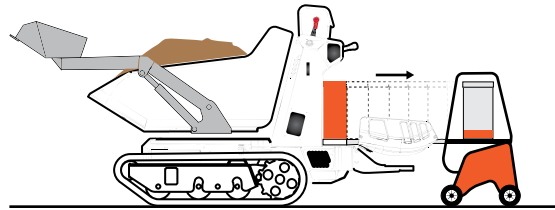

EXTRACT THE BATTERY

3

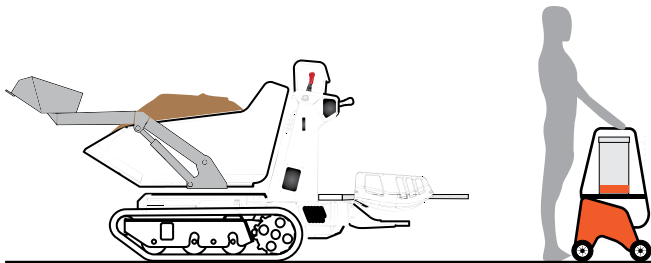

CHANGE CART

4

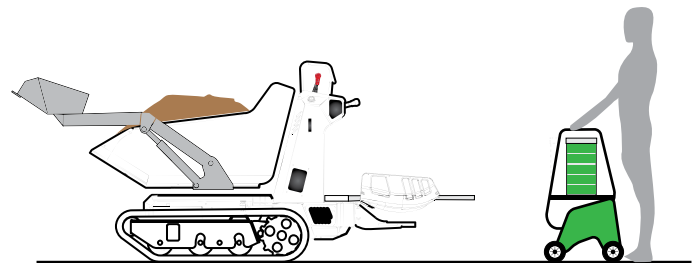

CART WITH CHARGED BATTERY

5

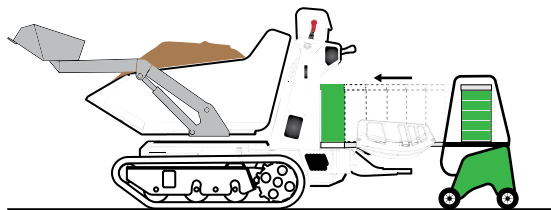

INSERT THE BATTERY

6

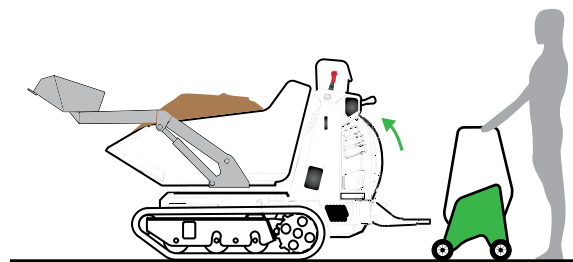

CLOSE THE BONNET

Another innovation of Cormidi is

a Removable Battery Pack. 

The battery we developed has a very large battery life, but when it does discharge it is possible to

change it in **less than 3 minutes** 

as you would with a normal mobile phone.

This allows you to work

24H without stopping. 

DUMPER (RI)

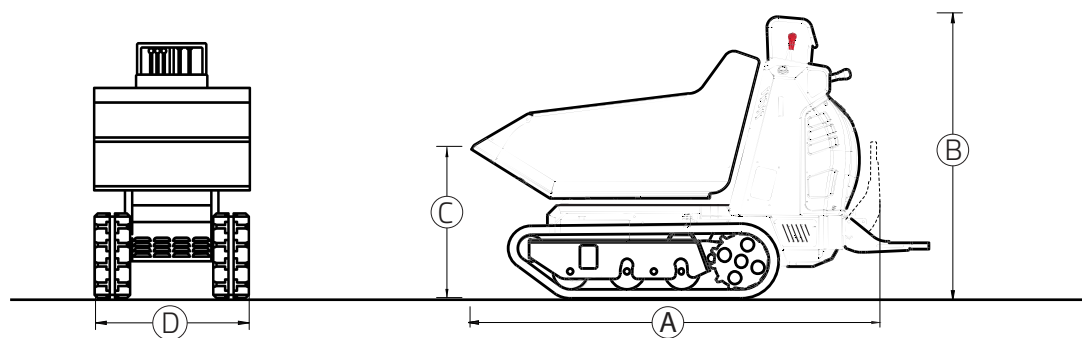

	mm	inch.
A	1926	A 75.8
B	1336	B 52.6
C	739	C 29.1
D	810	D 31.9

OPERATIVE
CAPACITY

TOTAL
WEIGHT

STRUCK

HEAPED SAE

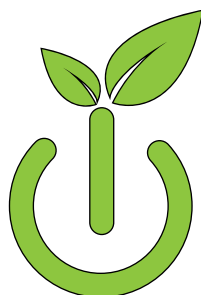

GreenPower
E C O L O G Y

Lithium

800 kg

1764 Lb

541 kg

1193 Lb

0,28 m³

0.33 yd³

0,36 m³

0.45 yd³

CORMIDI

CBS
MINI TRACK DUMPER



DRIVE THE CHANGE

AGRI (RIA)

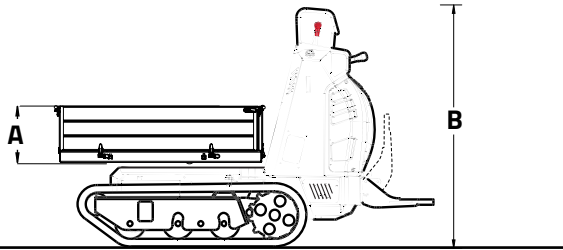
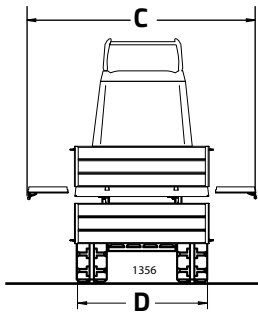

	mm	inch.
A	305	12.0
B	1336	52.6
C	1356	53.4
D	810	31.9

OPERATIVE
CAPACITY

TOTAL
WEIGHT

STRUCK

HEAPED SAE

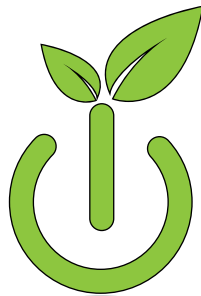

GreenPower
E C O L O G Y

Lithium

800 kg

1764 Lb

536 kg

1182 Lb

0,19 m³

0.25 yd³

0,31 m³

0,41 yd³

CORMIDI

CBS
MINI TRACK DUMPER



DRIVE THE CHANGE

DUMPER (RI-Poly)

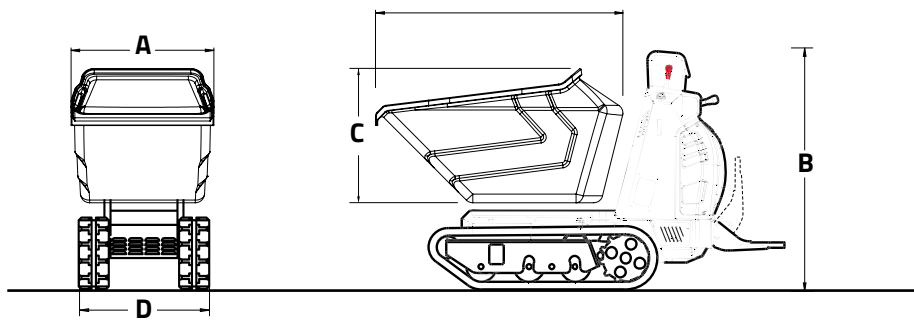

	mm	inch.
A	777	28.8
B	1336	52.6
C	730	29.1
D	810	31.9
F	1347	53.0

OPERATIVE
CAPACITY

TOTAL
WEIGHT

STRUCK

HEAPED SAE



Lithium

800 kg

1764 Lb

511 kg

1127 Lb

0,39 m³

0.51 yd³

0,53 m³

0.69 yd³

CORMIDI

CBS
MINI TRACK DUMPER



DRIVE THE CHANGE

DUMPER (RIX-Poly)

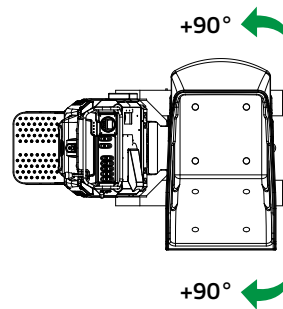
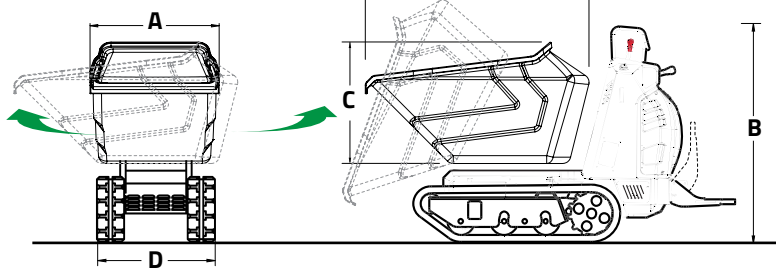

	mm	inch.
A	777	28.8
B	1336	52.6
C	730	29.1
D	810	31.9
F	1347	53.0

OPERATIVE
CAPACITY

TOTAL
WEIGHT

STRUCK

HEAPED SAE

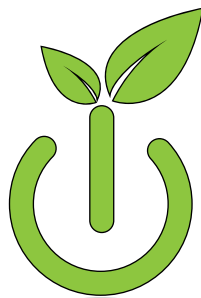

GreenPower
E C O L O G Y

Lithium

800 kg

1764 Lb

581 kg

1281 Lb

0,39 m³

0.51 yd³

0,53 m³

0.69 yd³

CORMIDI

CBS
MINI TRACK DUMPER



DRIVE THE CHANGE

SELF LOADING (AC-ACW)

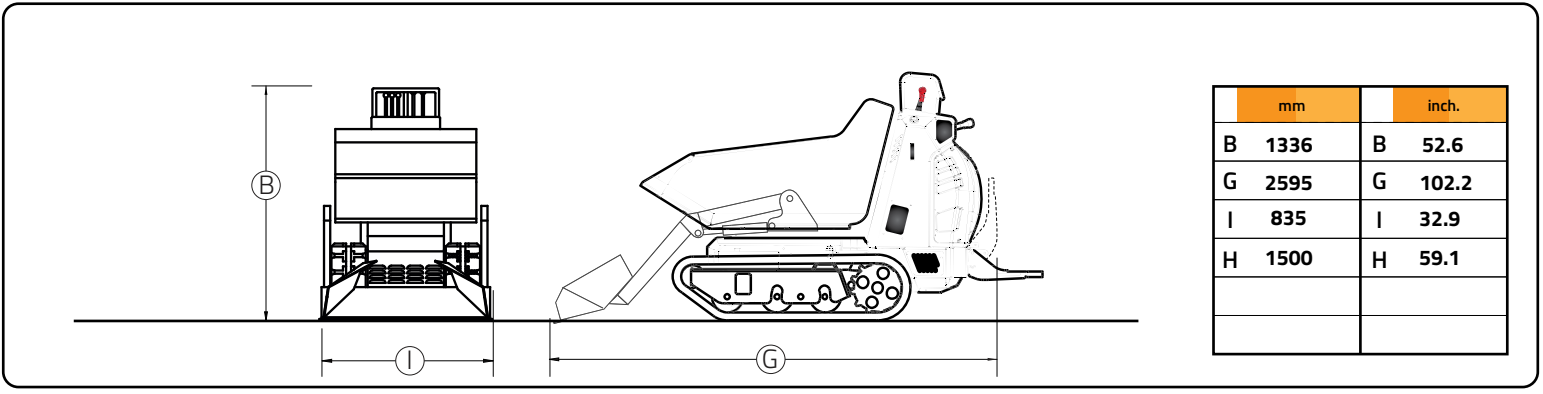

OPERATIVE CAPACITY	 <p>GreenPower E C O L O G Y</p>	Lithium 800 kg 1764 Lb
TOTAL WEIGHT		637 kg 1404 Lb
STRUCK		0,25 m³ 0.33 yd³
HEAPED SAE		0,34 m³ 0.45 yd³

CORMIDI

CBS
MINI TRACK DUMPER



HI-TIP (HI)

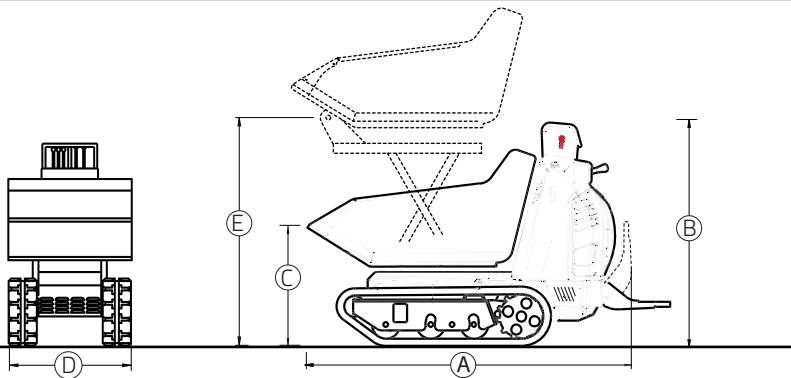

	mm	inch.
A	1926	A 75.8
B	1336	B 52.6
C	739	C 29.1
D	810	D 31.9
E	1500	E 59.1

OPERATIVE
CAPACITY

TOTAL
WEIGHT

STRUCK

HEAPED SAE

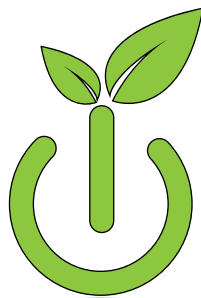

GreenPower
ECOLOGY

Lithium

800 kg

1764 Lb

643 kg

1418 Lb

0,28 m³

0.33 yd³

0,36 m³

0.45 yd³

CORMIDI

CBS
MINI TRACK DUMPER



DRIVE THE CHANGE

HI-TIP AND SELF LOADING (HIAC-HIACW)

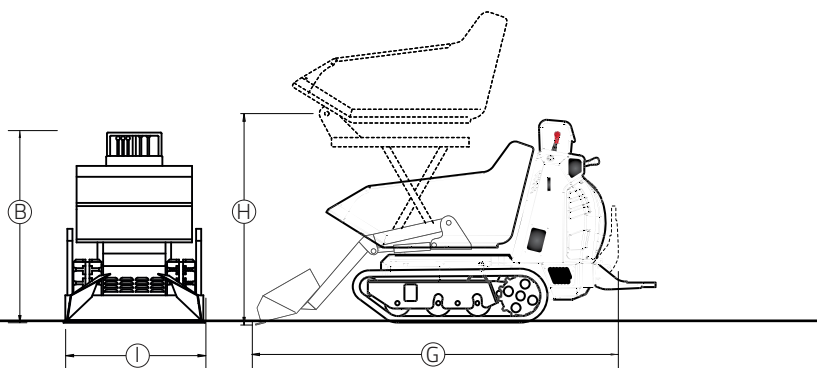

	mm	inch.
B	1336	B 52.6
G	2595	G 102.2
I	835	I 32.9
H	1500	H 59.1

OPERATIVE
CAPACITY

TOTAL
WEIGHT

STRUCK

HEAPED SAE

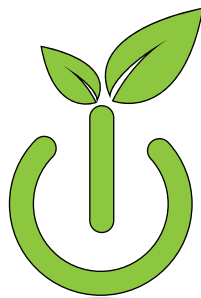

GreenPower
E C O L O G Y

Lithium

800 kg

1764 Lb

740 kg

1631 Lb

0,25 m³

0.33 yd³

0,34 m³

0.45 yd³

CORMIDI

CBS
MINI TRACK DUMPER



DRIVE THE CHANGE

CONCRETE MIXER (AC)

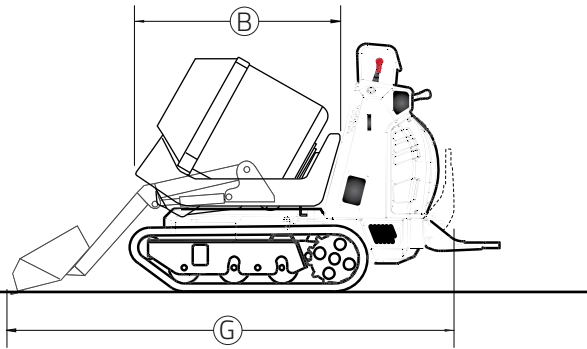
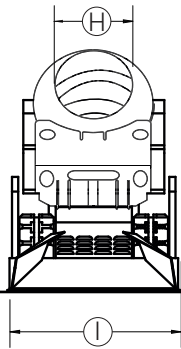

	mm		inch.
B	1125	B	44.3
G	2595	G	102.2
I	835	I	32.9
H	425	H	16.7

OPERATIVE CAPACITY

TOTAL WEIGHT

GROSS CAPACITY

NET CAPACITY

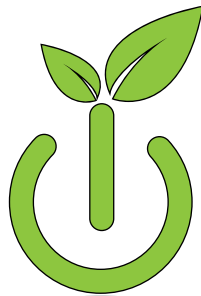

GreenPower
E C O L O G Y

Lithium

800 kg

1764 Lb

240 L

63.4 gal

130 L

34.3 gal

CORMIDI

CBS
MINI TRACK DUMPER



DRIVE THE CHANGE

MINI LOADER (ML)

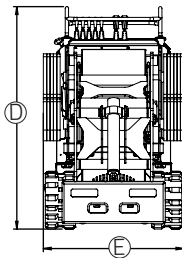
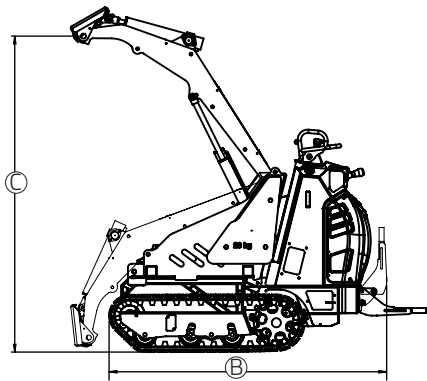

	mm	inch.
B	1654	65.1
C	1884	74.2
D	1326	52.2
E	837	33.0

OPERATIVE CAPACITY

TOTAL WEIGHT



Lithium

800 kg

1764 Lb

800 kg

1764 Lb

TIPPING CAPACITY

WITHOUT COUNTERWEIGHT

461 kg

1.016 Lb

WITH COUNTERWEIGHT 120 KG

643 kg

1418 Lb

GROUND PRESSURE

0,341 kg/cm²

4.84 psi

CORMIDI

CBS
MINI TRACK DUMPER



DRIVE THE CHANGE

TECHNICAL DATA

METRIC | U.S.

Lithium

ENGINE	
Power 100%	5500w
Power Peak	6500w
Voltage	24 VAC
Current	360 A
Can Bus Tecnolgy	Yes

TRANSMISSION	
Type	Hydrostatic
Hydraulic pump	2 variable piston pump

TRACKS	
Crawler width	180 mm (7.1 in)
Rocking rollers	Yes

HYDRAULIC SYSTEM	
Hydraulic pump	Gear pump
	1x7 l/min (1x1.84 gpm)
max pressure	130 bar (1886 psi)

PERFORMANCE AND DIMENSIONS	
Max. travel speed	(5 Kmh) (3.1 mph)
Operative weight	800 kg (1762 LB)
Setting Display touch screen	Yes
Parking brake	Yes
Vessel contents	0.28 m ³ (0.37 yd ³) 0.53 m ³ (0.69 yd ³)

BATTERY	
Capacity	up to 9,6 kwh
Volt	24
Type	LiFeP04
Duty Cycle Life	3000
Can Bus Tecnolgy	Yes

CHARGER BATTERY	
Monofase 220/110V	4,5hr 100%
Treefase 380V	2,2 hr 100%

Attachments

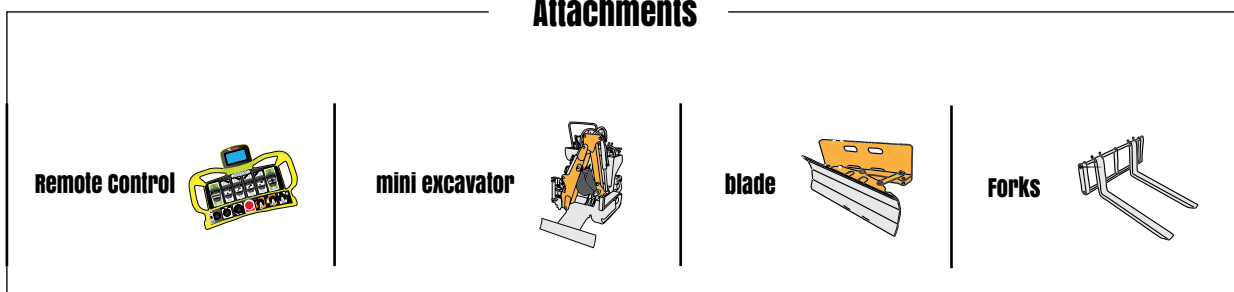



DRIVE THE CHANGE

Please note: The machines and accessories depicted in brochures and catalogues can vary from version to version, therefore please consult your distributor for a description of standard accessories and options available for each model. Cormidi reserves the right to change or to modify the specification of the machines without warning. The photos in catalogues and brochures represent the Cormidi machines in production at time of printing. However, newer and upgraded models may look different to the photos shown in this catalogue or brochure.

 Via Fonte, 342 Roccadaspide
(SA) Italy
ph. +39 0828 943688
fax +39 0828 943963

CORMIDI

25 Broad St, Norwalk 
CT 06851, USA
ph. +1 203-846-6120
art@cormidiusa.com